

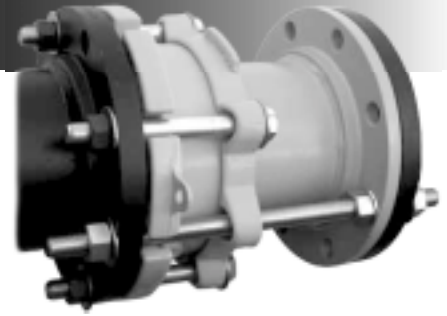

# DISMANTLING JOINT

ROBAR  BAKER



## APPLICATIONS:

ROBAR **Dismantling Joint** allows for adjustability once the flange and other flange fitting is in place. Dismantling Joints provide longitudinal adjustment which allows for future modifications and adjustments. The dismantling joint provides an easier way of repairing or doing maintenance on the flanged pipe system.

## SIZES AVAILABLE:

4" to 96" Nominal Pipe OD. Contact Robar for larger sizes.

## MATERIAL SPECIFICATIONS:

Flange Spool: AWWA C207 Class D Flange 150 lb Bolt Pattern (other flanges available)  
 End Ring & Body: 4" - 12" Cast Ductile Iron, 14" and larger Carbon Steel ASTM A36  
 (4" - 12" available in Carbon Steel as well)  
 Gaskets: SBR (Buna S) Rubber (other compounds available)  
 Fasteners: 7404DJ / 7504DJ / 7808DJ / 7908DJ - High Strength Low Alloy Fasteners or NC Cast Ductile Iron  
 7406DJ / 7506DJ / 7806DJ / 7906DJ - T-304 Stainless Steel  
 (other types of stainless steel available)  
 Tie Rods: ASTM A193 Gr B7 per M11 (stainless steel is available)  
 Coating: 7404DJ / 7406DJ / 7808DJ / 7806DJ - Two coats of enamel  
 7504DJ / 7506DJ / 7908DJ / 7906DJ - Fusion Bonded Epoxy  
 (other types of epoxy available)

## HOW TO ORDER:

Determine the product number (**7808DJ**, **7806DJ** or **7906DJ**), nominal size, actual OD of pipe, and pressure rating and then use the appropriate order code as shown in the following example:

To connect 16.00" OD steel pipe with 16" Flanges, that is epoxy coated and stainless steel bolts, the ordering code is:

**7906DJ** - 16" x 16.00"  
 product Flange size OD (Actual)  
 number

i.e. **7906DJ - 16 x 16.00" OD**

**ROBAR INDUSTRIES LTD. - BRITISH COLUMBIA**

Phone: (604) 591 - 8811  
Toll Free: (800) 663 - 6553  
Fax: (604) 591 - 5288

**LES PRODUITS INDUSTRIELS ROBAR INC. - QUEBEC**

Phone: (450) 641 - 9525  
Toll Free: (800) 315 - 9525  
Fax: (450) 641 - 4894

Website: [www.robarindustries.com](http://www.robarindustries.com) / E-mail: [waterworks@robarindustries.com](mailto:waterworks@robarindustries.com)