



2616 BOSS PAD SERVICE SADDLE

The 2616 Boss Pad Service Saddle provides you with a durable and reliable seal on all types of pipe. The Boss Pad gasket's superior design allows for a field friendly installation by having an anchored gasket seat and a wide foot print to reduce the risk of gasket roll during installation.

Made from
304L stainless
steel (ASTM?)

2616 Boss Pad
Service Saddle
is NSF 61
certified

Fully passivated
GMAW/GTAW
welds

Boss Pad reduces
risk of "gasket roll"

Boss Pad Gasket provides
"Anchored" design

Longer studs to
allow for ease of
installation

improved anti-
galling compound on
stainless steel
5/8 heavy hex nuts

Performance Under Pressure

waterworks@robarindustries.com

ROBAR INDUSTRIES LTD. - BRITISH COLUMBIA
Tel 604.591.8811 Toll Free 1.800.663.6553 Fax 604.591.5288

www.robarindustries.com

LES PRODUITS INDUSTRIELS ROBAR INC. - QUEBEC
Tel 450.641.9525 Toll Free 800.315.9525 Fax 604.641.4894



2616 BOSS PAD SERVICE SADDLE

MATERIAL SPECIFICATIONS

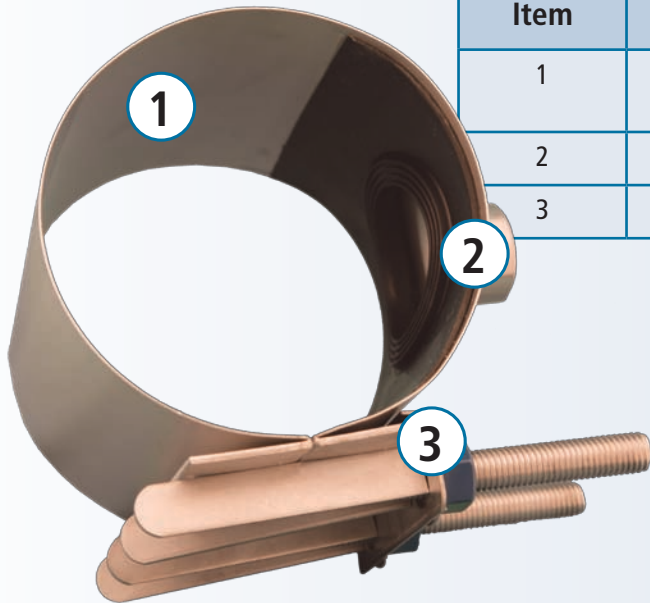

Item	Part Name	Material	Specification
1	Saddle Body	Fully Passivated 304 Stainless Steel	ASTM ???
2	Gasket	SBR**	AWWA C111
3	Fasteners	5/8 NC 304 SS	AWWA C111

**Due to the characteristics of HDPE please contact Robar for use of the 2616 Boss Pad saddle on HDPE*
***Other compounds available on request*

The 2616 Boss Pad is suitable for use on Steel, HDPE*, PVC (C 900, IPS PVC), DI, CI & Asbestos Cement pipe. For best long term seal results please follow installation instructions provided with each saddle.

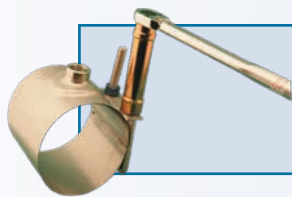

Robar requires the use of a gasket lubricant along with 80 ft lbs of torque for a successful installation



All dimensions are in inches

waterworks@robarindustries.com

ROBAR INDUSTRIES LTD. - BRITISH COLUMBIA
 Tel 604.591.8811 Toll Free 1.800.663.6553 Fax 604.591.5288

www.robarindustries.com

LES PRODUITS INDUSTRIELS ROBAR INC. - QUEBEC
 Tel 450.641.9525 Toll Free 800.315.9525 Fax 604.641.4894