



6906 / 6908

CARBON STEEL TAPPING SLEEVE

APPLICATIONS

ROBAR 6906 / 6908 Tapping Sleeves are used to make a branch outlet off a main supply line on Steel, Ductile Iron, Cast Iron, Asbestos Cement, C900 and HDPE with an SDR number 17 and less (13.5, 11 & 9). Not for use on Concrete Pressure Pipe.

MATERIAL SPECIFICATIONS

- Body:** Shell: Cast Ductile Iron
Outlet Pipe: Schedule 40 Carbon Steel or equivalent
- Flange:** Carbon Steel as per AWWA C207 class D. Mechanical Joint flange available
- Gaskets:** Nitrile (NBR) Rubber
- Fasteners:** 6908 - 3/4" NC HSLA
6906 - 3/4" NC T-304 Stainless Steel. Nuts coated with anti-galling compound. Torque is 80ft. lbs
- Test Plug:** 3/4" NPT Mild Steel
- Coating:** 6908/6906 - Corrosion Protective Epoxy coating
- PSI Rating:** 175 psi

Meets AWWA C223 Standards

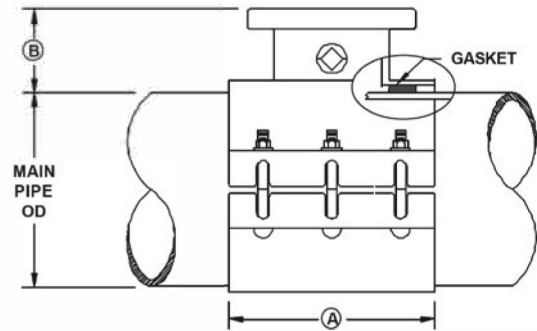
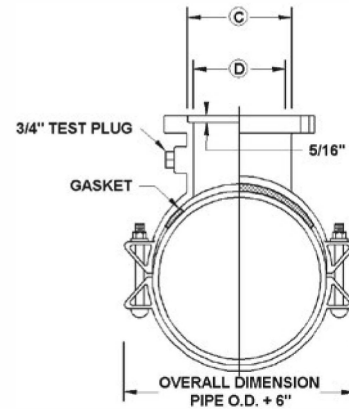

TAPPING SLEEVE DATA

NOMINAL OUTLET SIZE	A	B	C (DIA.)	D (DIA.)	BOLT QTY.	BOLT SIZE
3	12	5.00	4.06	3	6	3/4
4	12	5.00	5.06	4	6	3/4
6	12	5.00	7.06	6	6	3/4
8	16	5.13	9.06	8	8	3/4
10	20	5.50	11.06	10	10	3/4
12	20	5.75	13.06	12	10	3/4

HOW TO ORDER

Determine the product number (6906, etc.), nominal main size, nominal outlet size and the high limit number (see table above) and then order using the appropriate ordering code as shown in the following example.

If an Epoxy coated mild steel tapping sleeve is required to install a 8" outlet on a 12" Ductile Iron pipe (13.20" OD), the ordering code is:

Product Number	Nominal Main Size	Nominal Outlet Size	Actual Main OD
----------------	-------------------	---------------------	----------------

6906 - 12" x 8" - 13.30

i.e. 6906 - 12 x 8 - 13.30

Carbon Steel tapping sleeves rated for 175 PSI working pressure (contact Robar for higher pressure ratings).



This product is tested and certified by WQA to NSF/ANSI standard 61

ROBAR INDUSTRIES LTD.

www.robarindustries.com
waterworks@robarindustries.com

Surrey, British Columbia
Phone: 1-800-663-6553

Saint-Bruno, Quebec
Phone: 1-800-315-9525



6906 / 6908

CARBON STEEL TAPPING SLEEVE

NOMINAL PIPE SIZE	BY X	OUTLET SIZE	FITTING LENGTH	NUMBER OF BOLTS	APPROXIMATE SHIPPING WEIGHT		WORKING RANGE			
					LBS.	KG.	LOW	HIGH		
6	X	3	12	6	46	21	6.90	7.20		
		4			50	23				
		6**			50	23				
8	X	3	12	6	61	28	8.50	8.90		
		4			65	29				
		6			80	36				
		8**	16	8	90	41			9.30	9.70
10	X	3	12	6	64	29	9.70	10.10		
		4			68	31				
		6			70	32				
		8	16	8	92	42			10.50	10.90
		10**	20	10	118	54			10.90	11.30
12	X	3	12	6	88	40	12.10	12.50		
		4			92	42				
		6			100	45				
		8	16	8	115	52			12.50	12.90
		10	20	10	130	59			12.90	13.30
		12**	20	10	170	77			13.30	13.60
14	X	3	12	6	91	41	13.60	14.05		
		4			95	43				
		6			102	56				
		8	16	8	124	68			14.05	14.50
		10	20	10	150	91			14.50	14.95
		12	20	10	200	102			14.95	15.40
16	X	3	12	6	101	46	15.75	16.15		
		4			105	47				
		6			114	62				
		8	16	8	136	74			16.15	16.60
		10	20	10	162	96			16.60	17.05
		12	20	10	212	108			17.05	17.50
18	X	3	12	6	128	58	17.40	17.85		
		4			132	60				
		6			154	70				
		8	16	8	180	82			17.40	17.85
		10	20	10	230	105			18.30	18.75
		12	20	10	255	116			18.75	19.20
20 - 22	X	3	12	6	133	60	19.20	19.65		
		4			137	62				
		6			159	72				
		8	16	8	185	84			19.20	19.65
		10	20	10	235	107			21.40	21.90
		12	20	10	260	118			21.90	22.15
24	X	3	12	6	163	74	22.70	23.25		
		4			167	76				
		6			189	86				
		8	16	8	215	98			22.70	23.25
		10	20	10	265	120			23.60	24.15
		12	20	10	290	132			24.15	24.70

For a 4" tapping sleeve, see **6606** or **6506**.

All dimensions are in inches.

Note: * The high limit of the range is used in the ordering code.

** When ordering size on size Tapping Sleeves, a 1/2" undersize cutter is required. Size on size for IPS size is unavailable.

- Other working ranges are available on request.

ROBAR INDUSTRIES LTD.

www.robarindustries.com
waterworks@robarindustries.com

Surrey, British Columbia
Phone: 1-800-663-6553

Saint-Bruno, Quebec
Phone: 1-800-315-9525